



Nine®

Super Power Drill Super Drill Chamfer Mill

Inserts are Identical for
SD & SPD & Chamfer Mill

We always offer more and better...

Reliable quality!

Efficient service!

Valuable product!

Attractive price!

Copyright © Jimmore International Corp. 2010.09 Cat. No. SPD,SD&CM.01 GB-500MC



AGT
LIMITED
Advanced Carbide Tooling
LIMITED

Sketchley Meadows Business Park,
Hinckley Leicestershire, LE10 3EZ
TEL: 01455 234000 FAX: 01455 234022
E-mail: info@advancedcarbide tooling.co.uk
<http://www.advancedcarbide tooling.co.uk>

Distributor :

Patented

Taiwan	216309
China	EL 02220067.3, EL 02257836.6
Japan	3103139
Germany	NR20208062.5, NR20217544.8
USA	7.108.460



Cat. No.:01



A True Engineering Challenge!

It is no doubt that deep hole drilling by indexable drill is always a challenge of the drill makers.

Nine9 "Super Power Drill", featuring by patented indexable center pilot insert design, which is the first time in the world, helping to achieve the cost-effective and good performance, making deep hole drilling up to 10xD possible.

With patented center pilot insert which aids accurate and steady deep hole drilling. Long tool life and better surface finish are achievable.

Patented Center Pilot Insert:



CD6-NC40



CD8-NC40



CD6-NC2032



CD8-NC2032

Features:

- Special geometry design delivers the benefits of the center drill in guiding position and eliminates the defects caused by the chip flow from the gap between the center drill and insert.
- High precision fully ground and edge honing to increase tool life and surface finish.
- Patented insert pocket to absorb the cutting forces, supporting the center pilot insert functional while drilling.

Special pocket design for center pilot insert.



Backup edge to absorb cutting force.

Supporting edge
Cutting forces

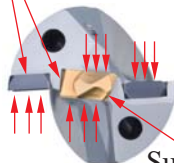

Cutting force
Supporting edge

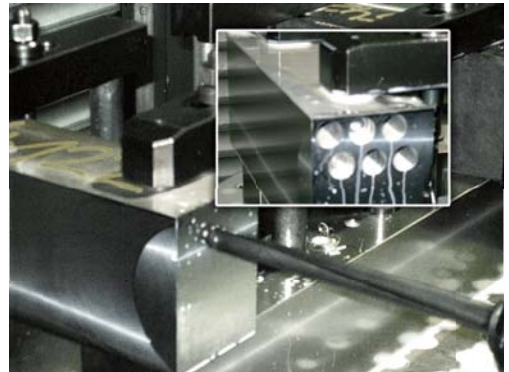

Patented

Periphery Inserts:



19-21 mm



22-34 mm



35-40 mm

Features:







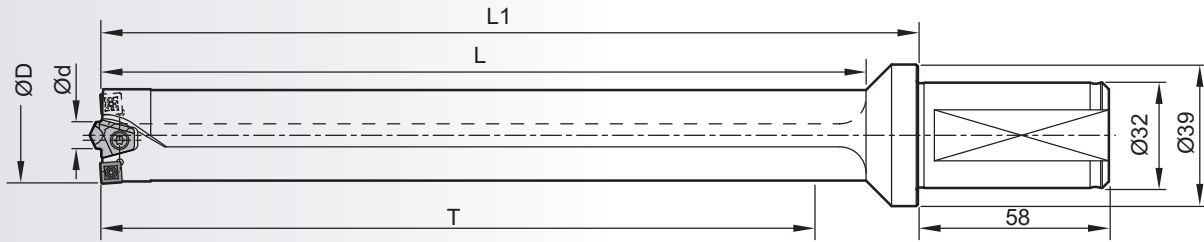













- Each insert has 4 cutting edges.
- The inserts are designed for optimum chip breaking and good edge preparation for longer tool life.
- Dia. 19-26mm: one periphery insert is required
- Dia. 27-40mm: two periphery inserts are required.





5D-10D Super Power Drill 19mm~40mm



5D-10D

Ordering code	Diameter D mm(inch)	T	L	L1	Insert / Screw / Key										
					Center	Periphery									
00-99307-19100	19 (0.748")	100	119	134	 99307-CD6 x 1 pc. NS-35080 NK-T15 Torque: 2.5Nm	 N9GX04T002 x 1 pc. NS-18037 / NK-T6 Torque: 0.6Nm									
00-99307-19150		150	169	184											
00-99307-19200		200	219	239											
00-99307-20100	20 (0.787")	100	120	134		 99307-CD8 x 1 pc. NS-35120 NK-T15 Torque: 2.5Nm	 N9GX05T103 x 1 pc. NS-20045 NK-T6 Torque: 0.8Nm								
00-99307-20150		150	170	184											
00-99307-20200		200	220	239											
00-99307-21100	21 (0.827")	100	120	134			 N9GX060204 x 1 pc. NS-22055 NK-T7 Torque: 1.0Nm	 N9GX060204 x 2 pcs. NS-22055 NK-T7 Torque: 1.0Nm							
00-99307-21150		150	170	184											
00-99307-21200		200	220	239											
00-99307-22100	22 (0.866")	100	125	139					 N9GX060204 x 2 pcs. NS-22055 NK-T7 Torque: 1.0Nm	 N9GX060204 x 2 pcs. NS-22055 NK-T7 Torque: 1.0Nm					
00-99307-22150		150	175	189											
00-99307-22200		200	225	239											
00-99307-23100	23 (0.905")	100	125	139							 N9GX060204 x 2 pcs. NS-22055 NK-T7 Torque: 1.0Nm	 N9GX060204 x 2 pcs. NS-22055 NK-T7 Torque: 1.0Nm			
00-99307-23150		150	175	189											
00-99307-23200		200	225	239											
00-99307-24100	24 (0.945")	100	126	139									 N9GX060204 x 2 pcs. NS-22055 NK-T7 Torque: 1.0Nm	 N9GX060204 x 2 pcs. NS-22055 NK-T7 Torque: 1.0Nm	
00-99307-24150		150	176	189											
00-99307-24200		200	226	239											
00-99307-24250	250	276	289												
00-99307-25100	25 (0.984")	100	126	139	 N9GX060204 x 2 pcs. NS-22055 NK-T7 Torque: 1.0Nm										 N9GX060204 x 2 pcs. NS-22055 NK-T7 Torque: 1.0Nm
00-99307-25150		150	176	189											
00-99307-25200		200	226	239											
00-99307-25250	250	276	289												
00-99307-26150	26 (1.024")	150	176	189		 N9GX060204 x 2 pcs. NS-22055 NK-T7 Torque: 1.0Nm									
00-99307-26200		200	226	239											
00-99307-26250		250	276	289											
00-99307-27150	27 (1.630")	150	181	198			 N9GX060204 x 2 pcs. NS-22055 NK-T7 Torque: 1.0Nm	 N9GX060204 x 2 pcs. NS-22055 NK-T7 Torque: 1.0Nm							
00-99307-27200		200	231	248											
00-99307-27250		250	281	298											
00-99307-28150	28 (1.102")	150	181	198					 N9GX060204 x 2 pcs. NS-22055 NK-T7 Torque: 1.0Nm	 N9GX060204 x 2 pcs. NS-22055 NK-T7 Torque: 1.0Nm					
00-99307-28200		200	231	248											
00-99307-28250		250	281	298											
00-99307-29150	29 (1.142")	150	182	198							 N9GX060204 x 2 pcs. NS-22055 NK-T7 Torque: 1.0Nm	 N9GX060204 x 2 pcs. NS-22055 NK-T7 Torque: 1.0Nm			
00-99307-29200		200	232	248											
00-99307-29250		250	282	298											
00-99307-29300	300	332	348												

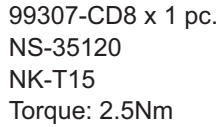
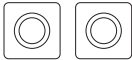
Ordering code	Diameter D mm(inch)	T	L	L1	Insert / Screw / Key			
					Center	Periphery		
00-99307-30150	30 (1.181")	150	182	198				
00-99307-30200		200	232	248				
00-99307-30250		250	282	298				
00-99307-30300		300	332	348				
00-99307-31150	31 (1.220")	150	188	198				
00-99307-31200		200	238	248				
00-99307-31250		250	288	298				
00-99307-31300		300	338	348				
00-99307-32150	32 (1.260")	150	188	203				
00-99307-32200		200	238	253				
00-99307-32250		250	288	303				
00-99307-32300		300	338	353				
00-99307-33150	33 (1.300")	150	189	203				
00-99307-33200		200	239	253				
00-99307-33250		250	289	303				
00-99307-33300		300	339	353				
00-99307-34150	34 (1.339")	150	189	203				
00-99307-34200		200	239	253				
00-99307-34250		250	289	303				
00-99307-34300		300	339	353				
00-99307-34350		350	389	403				
00-99307-35200	35 (1.378")	200	245	258				
00-99307-35250		250	295	308				
00-99307-35300		300	345	358				
00-99307-35350		350	395	408				
00-99307-36200	36 (1.417")	200	245	258				
00-99307-36250		250	295	308				
00-99307-36300		300	345	358				
00-99307-36350		350	395	408				
00-99307-37200	37 (1.457")	200	246	258				
00-99307-37250		250	296	308				
00-99307-37300		300	346	358				
00-99307-37350		350	396	408				
00-99307-38200	38 (1.496")	200	246	258				
00-99307-38250		250	296	308				
00-99307-38300		300	346	358				
00-99307-38350		350	396	408				
00-99307-39200	39 (1.535")	200	247	258				
00-99307-39250		250	297	308				
00-99307-39300		300	346	358				
00-99307-39350		350	397	408				
00-99307-40200	40 (1.575")	200	247	258				
00-99307-40250		250	297	308				
00-99307-40300		300	347	358				
00-99307-40350		350	397	408				



**Smallest indexable drill from 10mm.
4 cutting edges per insert,
same insert for outer and inner insert.**

Main Features:

SMALLEST DIMENSION

3xD: Ø10 to Ø30 mm.

4xD: Ø16 to Ø30 mm.

SMALLER CUTTING CHIP

- The center and peripheral inserts are positioned in order to divide the cutting chips into smaller spiral shape. It helps the cutting chip to be removed faster and easier.
- Designed for high productivity, high speed cutting. Coolant supply is needed.

BETTER SURFACE FINISH AND BETTER DIAMETER ACCURACY

- Special insert positioning to balance the cutting forces, better surface finish and diameter accuracy are achievable.

Patent Pending

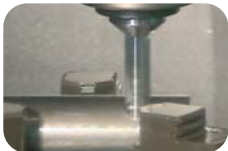

Cone



Half diameter



Plunge drilling



3xD and 4xD Tool Holder:

- The tool holder is made of high alloy steel, hardened and nickel plated.
- Coolant is supplied by 2-straight coolant holes to ensure enough coolant volume to flush out the cutting chips.
- The insert pockets are arranged to split the cutting chip which makes the cutting chip excavation more efficient.
- The flutes of the drill are non symmetrical there by increasing the rigidity of the tool holder.

Inserts:



- **Patented dual-relief angle insert**
Primary relief angle is to increase the toughness of the insert, secondary relief angle is to strengthen the axial feed rate.

FULLY GROUND DUAL-RELIEF INSERT, FOR IMPROVED SURFACE FINISH AND HIGHER FEED RATE.

SQUARE INSERT WITH 4 CUTTING EDGES, REDUCING COST PER INSERT.

CENTER AND PERIPHERAL INSERTS ARE IDENTICAL, REDUCING COST OF STOCK OF INSERT INVENTORY.

GRADES ARE AVAILABLE TO SUIT ALL MATERIALS.

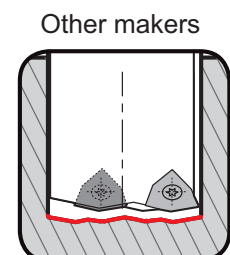
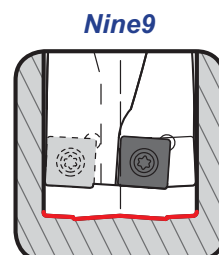

3xD Super Drill 10mm~30mm

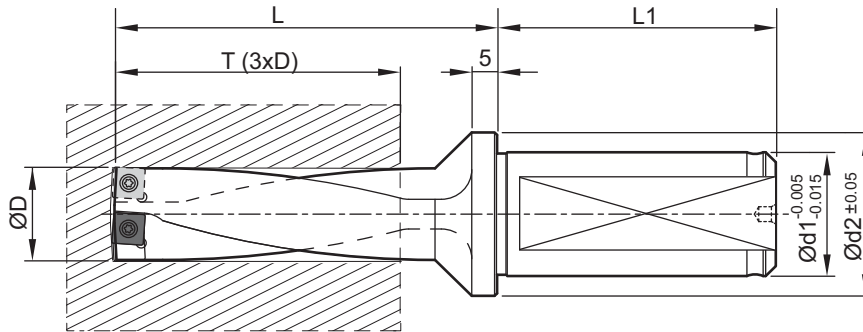

3D

Ordering code	D	T	L	d1	d2	L1	Insert Screw / Key	Radial Adjustment	D max
00-99313-10	10.0	30.0	49	20	27	49	N9GX04T002 NS-18037 NK-T6 Torque: 0.6Nm	0.25	10.5
00-99313-10.3	10.3	30.9	52	20	27	49		0.25	10.8
00-99313-10.5	10.5	31.5	52	20	27	49		0.25	11.0
00-99313-11	11.0	33.0	52	20	27	49		0.20	11.4
00-99313-11.5	11.5	34.5	55	20	27	49		0.20	11.9
00-99313-12	12.0	36.0	55	20	27	49		0.15	12.3
00-99313-12.5	12.5	37.5	58	20	27	49	0.15	12.8	
00-99313-13	13.0	39.0	58	20	27	49	N9GX05T103 NS-20045 NK-T6 Torque: 0.8Nm	0.30	13.6
00-99313-13.5	13.5	40.5	61	20	27	49		0.30	14.1
00-99313-14	14.0	42.0	61	20	27	49		0.25	14.5
00-99313-14.5	14.5	43.5	64	20	27	49		0.25	15.0
00-99313-15	15.0	45.0	64	20	27	49		0.20	15.4
00-99313-15.5	15.5	46.5	67	20	27	49		0.20	15.9
00-99313-16	16.0	48.0	74	25	31	49	N9GX060204 NS-22055 NK-T7 Torque: 1.0Nm	0.40	16.8
00-99313-16.5	16.5	49.5	76	25	31	55		0.40	17.3
00-99313-17	17.0	51.0	76	25	31	55		0.35	17.7
00-99313-17.5	17.5	52.5	78	25	31	55		0.35	18.2
00-99313-18	18.0	54.0	78	25	31	55		0.30	18.6
00-99313-18.5	18.5	55.5	80	25	31	55		0.30	19.1
00-99313-19	19.0	57.0	80	25	31	55	N9GX070304 NS-25060 NK-T7 Torque: 1.2Nm	0.25	19.5
00-99313-19.5	19.5	58.5	85	25	31	55		0.25	20.0
00-99313-20	20.0	60.0	85	25	31	55		0.50	21.0
00-99313-20.5	20.5	61.5	87	25	31	55		0.50	21.5
00-99313-21	21.0	63.0	87	25	31	55		0.45	21.9
00-99313-21.5	21.5	64.5	88	25	31	55		0.45	22.4
00-99313-22	22.0	66.0	88	25	31	55	N9GX090308 NS-30072 NK-T9 Torque: 2.0Nm	0.40	22.8
00-99313-22.5	22.5	67.5	90	25	31	55		0.40	23.3
00-99313-23	23.0	69.0	90	25	31	55		0.35	23.7
00-99313-23.5	23.5	70.5	92	25	31	55		0.35	24.2
00-99313-24	24.0	72.0	92	25	31	55		0.30	24.6
00-99313-25	25.0	75.0	114	32	43	58		0.50	26.0
00-99313-26	26.0	78.0	115	32	43	58	N9GX090308 NS-30072 NK-T9 Torque: 2.0Nm	0.50	27.0
00-99313-27	27.0	81.0	117	32	43	58		0.40	27.8
00-99313-28	28.0	84.0	126	32	43	58		0.40	28.8
00-99313-29	29.0	87.0	127	32	43	58		0.30	29.6
00-99313-30	30.0	90.0	130	32	43	58		0.30	30.6

* Other sizes are available on request.

4xD Super Drill 16mm~30mm

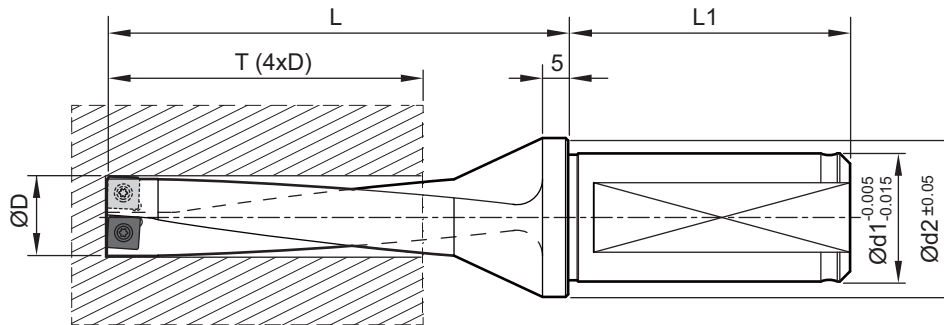

4D

Ordering code	D	T	L	Ød1	Ød2	L1	Insert Screw / Key	Radial Adjustment	D max
00-99314-16	16	64	90	25	31	55	N9GX060204	0.40	16.8
00-99314-17	17	68	93	25	31	55	NS-22055	0.35	17.7
00-99314-18	18	72	96	25	31	55	NK-T7	0.30	18.6
00-99314-19	19	76	99	25	31	55	Torque: 1.0Nm	0.25	19.5
00-99314-20	20	80	105	25	31	55	N9GX070304 NS-25060 NK-T7 Torque: 1.2Nm	0.50	21.0
00-99314-21	21	84	108	25	31	55		0.45	21.9
00-99314-22	22	88	110	25	31	55		0.40	22.8
00-99314-23	23	92	113	25	31	55		0.35	23.7
00-99314-24	24	96	116	25	31	55	N9GX090308 NS-30072 NK-T9 Torque: 2.0Nm	0.30	24.6
00-99314-25	25	100	139	32	43	58		0.50	26.0
00-99314-26	26	104	141	32	43	58		0.50	27.0
00-99314-27	27	108	144	32	43	58		0.40	27.8
00-99314-28	28	112	154	32	43	58		0.40	28.8
00-99314-29	29	116	156	32	43	58		0.30	29.6
00-99314-30	30	120	160	32	43	58	0.30	30.6	

Eccentric Ring

- Adjustable range: $E = \pm 0.2$ mm
- For hole diameter adjustment on Machining Center.
- For center height adjustment of CNC Lathe.

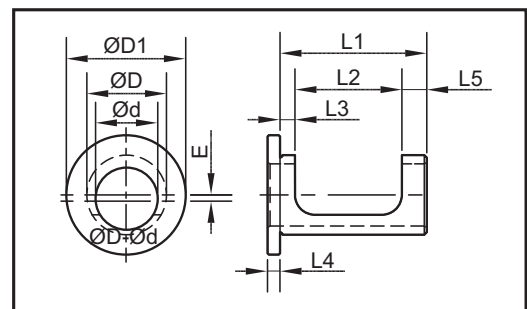

Ordering Code	Part No.	ØD	Ød	ØD1	L1	L2	L3	L4	L5
00-99302-2520	LS25-ID20	25	20	41	43	33	3	4	7
00-99302-3225	LS32-ID25	32	25	48	59	41	6	5	12
00-99302-4032	LS40-ID32	40	32	58	69	43	6	5	20

New Nine9 Chamfer Mill

is designed for chamfering and countersinking with an indexable insert. The insert is a specifically designed for **use in high speed machining; the multiple flutes provide for increased feed rate, optimizing performance and reducing cutting time.**

The same insert can be used on super drill, super power drill and chamfer mills.

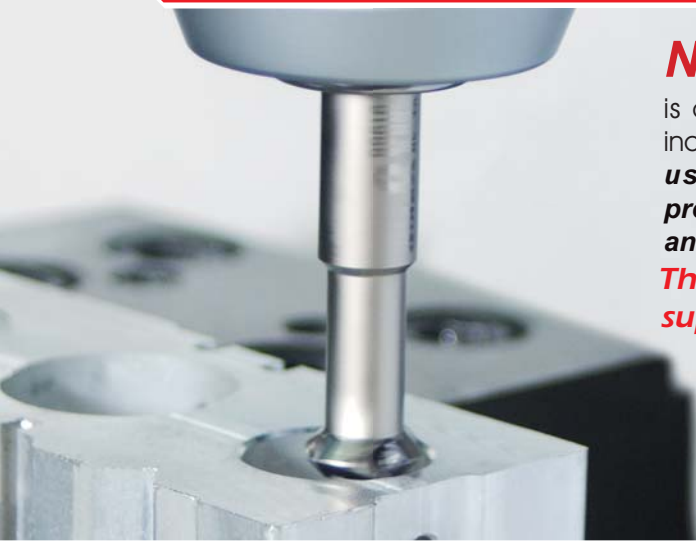

Features

- Smallest insert in the world for chamfering mill.
 - Smallest Indexable counter sink, diameter $\varnothing 7$ mm.
 - The insert has dual-relief angles, specially edge honed and optimized coated for high cutting speed.
 - Optimized the number of teeth on the holder to achieve higher feed rate.
 - For front and back chamfering.
- Eliminates 2nd operation or de-burring time.

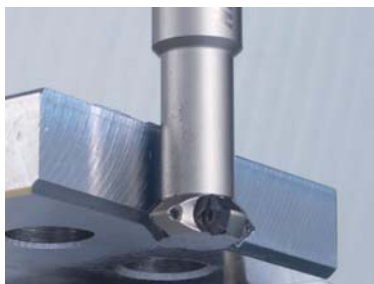
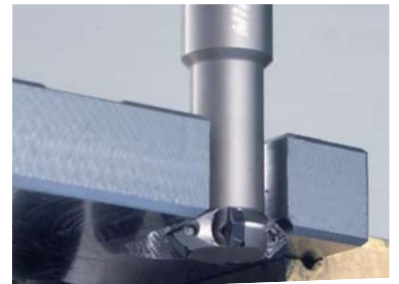
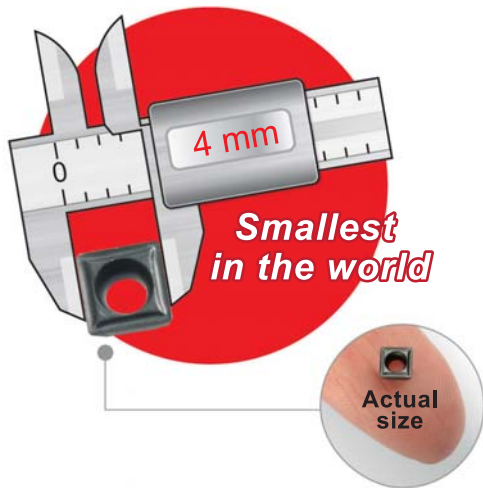

Applications

- 90° counter sink and 45° chamfering.
- For counter sink, circular chamfering, contour chamfering and face milling.



- Comparison with other manufacturers chamfer tool with larger insert(Sxxx1204) and Nine9 N9GX04 insert.

	Other makers with large insert	Nine9 chamfer mills
Chamfering	1 mm	1 mm
Feed rate mm/rev.	0.1	0.1
Cutter dia.	32 mm	11 mm
Cutter teeth	2	4
Vc m/min.	200	300
R.P.M	1990	8685
F mm/min	398	3474

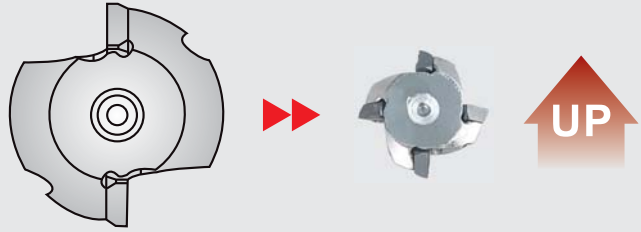

Feed Rate = Feed per Tooth x Spindle Speed x **No. of Flute** mm/min.

UP Spindle Speed = $\frac{\text{Cutting Speed} \times 1000}{\pi \times \text{Cmin.}}$

Cylindrical Shank Holders

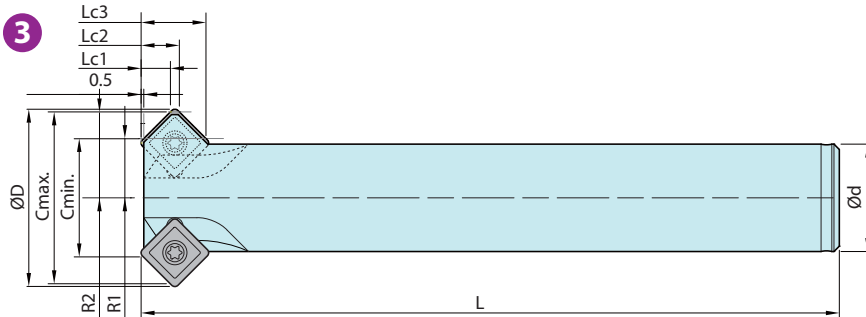
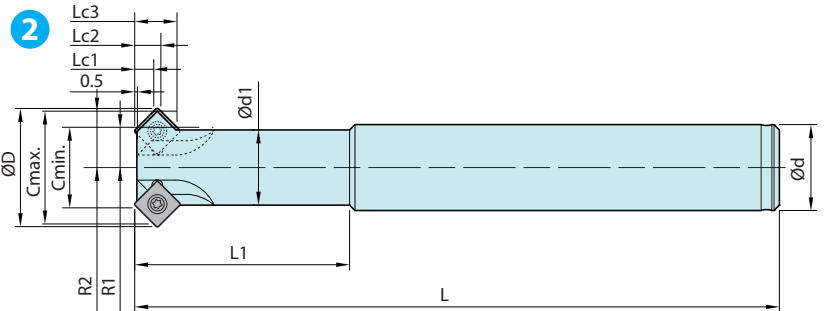
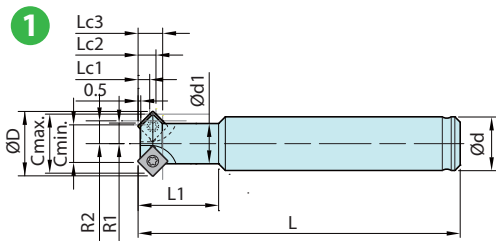

Fig.	Part No.	Type	Cmin. Ø	Cmax. Ø	Shank Ø	Ød1	ØD	R1	R2	L	L1	Lc1	Lc2	Lc3	Z	Insert Screw / Key
1	00-99616-C10	BC10-C07-60	7	11	10	7.5	12	3.8	4.3	60	15	2.6	2.9	5.0	2	N9GX04T002 NS-18037
2	00-99616-C20	BC12-C11-100	11	16	12	9.6	16.2	5.9	8	100	25	2.6	2.9	5.0	4	NK-T6 Torque:0.6Nm
2	00-99616-C30	BC16-C15-120	15	21	16	14	22	7.5	11.5	120	40	3.5	4.9	7.9	4	N9GX060204 NS-22055
2	00-99616-C40	BC20-C19-130	19	25	20	18	26	9.5	12.5	130	50	3.5	4.9	7.9	4	NK-T7 Torque:1.0Nm
3	00-99616-C50	BC20-C22-130	22	32	20	-	33	11	16	130	-	5.5	7.1	12.1	4	N9GX090308 NS-30072
2	00-99616-C52	BC25-C22-180	22	32	25	20	33	11	16	180	80	5.5	7.1	12.1	4	NK-T9 Torque:2.0Nm

Kit

Fig.	Part No.	Insert included	Holder included	Content
1	00-99616-C1020-32	N9GX04T002-NC2032	00-99616-C10	2 x holders + 10 inserts + 1 key
	00-99616-C1020-71	N9GX04T002-NC9071	+ 00-99616-C20	
2	00-99616-C3040-32	N9GX060204-NC2032	00-99616-C30	
	00-99616-C3040-71	N9GX060204-NC9071	+ 00-99616-C40	
3	00-99616-C5052-32	N9GX090308-NC2032	00-99616-C50	
	00-99616-C5052-71	N9GX090308-NC9071	+ 00-99616-C52	



Material Classification for Calculation

5D-10D

There are an extremely wide range of materials and different machining operations in the metal cutting industry. We follow the ISO material group and color to make brief information for calculation of the required power for **super power drill**, the main effective parameter is “**specified cutting force**”, please use following table and formula: (More detail of work piece material classification is listed in our website.)

ISO Class	Material Group	Material Type and description	Hardness HB	Strength N/mm ²	Specified cutting force kc N/mm ²
P	1.10	Carbon steel C<0.3%, free cutting steels	~125	500-850	1900
	1.20	Carbon steel C>0.3%	~150	850-1000	2100
	1.30	Low alloy steel C<0.3%	180	Up to 750	2100
	1.40	Low alloy steel C>0.3%	200	750-1200	2600
	1.50	High alloy steel	200	800-1200	2600
	1.60	Tool steel, harder steels for toughening. Martensitic stainless steels.	<230	850-1100	2200
	1.70	Casting steel			2900
M	2.10	Free cutting Stainless steel Austenitic stainless steels	200	490-700	2300
	2.20	Difficult Stainless steel Austenitic stainless steels and duplex	175	650-850	2450
K	3.10	Grey casting Iron	180	250-350	1100
	3.20	Malleable casting iron..	230	Up to 600	1200
	3.30	Nodular casting iron	250	Up to 800	1800
N	4.10	Al- alloys(Si<12%)	60	230-310	500
	4.20	Al-alloys(Si>12%)	75	150-200	750
	4.30	Non-ferrous materials, Zirconium, Magnesium, Copper alloys, etc.	100	150-200	800
	4.40	Carbon and graphite composites, plastics, wood, rubbers, etc.	-	-	-
S	5.10	Nickel-based heat-resistant alloys	250		3500
	5.20	Cobalt-based heat resistant alloys	350		4150
	5.30	Iron-based heat resistant alloys	250		3050
H	6.10	Tool steels and hardened steels	55HRC		4500
	6.20	Hardened cast iron	-	-	-

Formulas for Calculation of Machining Power Pc(Kw) :

$$P_c(\text{Kw}) = \frac{f \times V_c \times D \times K_c}{60 \times 10^3 \times \eta}$$

feed force(KN) Ff:

$$F_f = \frac{a_p \times f \times K_c}{2000}$$

Drilling torque (Md)
torque=(Nm)

$$M_d = \frac{f \times \pi \times D^2 \times K_c}{4000} \text{ Nm}$$

f= feed rate mm/rev.

Vc=cutting speed m/min.

D=drill diameter mm

Kc=specified cutting force N/mm²

η =power transmission efficiency of spindle (75%-85%)

Center Pilot Insert

5D-10D

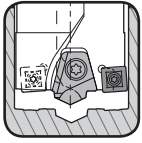

NC2032: K20F grade, AlTiN coated, fully ground, honed cutting edge.
For carbon steel & alloy steel C<0.3% and stainless steel.

NC40: P35 grade, TiN coated, fully ground, honed cutting edge.
For carbon steel & alloy steel C>0.3% and stainless steel.

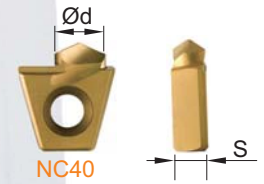

Ordering code		Dimensions			Insert Screw		Screw Key	
Code of insert	Grade	Ød	S	re	Ordering code	Torque	Ordering code	
99307-CD6	NC40	NC2032	6	4	-	NS-35080	2.5Nm	NK-T15
99307-CD8	NC40	NC2032	8	6	-	NS-35120	2.5Nm	NK-T15

Report of Surface Finish

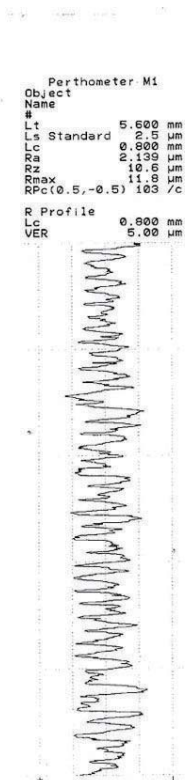

99307-29200

Insert: 99307-CD8

N9GX060204

MATERIAL: S45C

Vc=80 m/min

S=880 rpm

f=0.10 mm/z

F=88.0 mm/min

Ra= 2.139 µm

Rmax= 11.8 µm

Material: Carbon steel(S45C):

Super Power Drill: 00-99307-29200

Insert: 99307-CD8-NC40

and N9GX060204 NC2032

Cutting Data:

Vc= 80 m/min. Spindle speed=880 r.p.m.

f=0.10 mm/rev., F=88 mm/min.

Resulted:

Roughness: Ra=2.139 µm Rmax=11.8 µm



Periphery Insert of SD, SPD

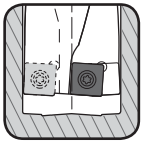

- Patented Dual-relief angle insert.
- Square insert, 4 cutting edges, reducing cost.
- Honed on the cutting edge, good chip breaking condition.
- Fully ground carbide insert.

NC2032: K20F grade, AlTiN coated, for carbon steel, alloy steel, casting iron, stainless steel and hardened steel up to HRC 50.

NC40: P35 grade, tougher insert with special chip breaker, TiN coated, for low carbon steel and stainless steel.
Only available for insert N9GX06020431 and N9GX09030831.

Patented
Dual-relief
angle insert

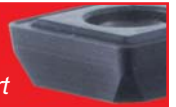

NC2032



NC40

Insert of Chamfer Mill

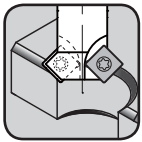

- Thanks to the patented specially ground dual-relief insert and optimized coating, higher feed rates and cutting speeds can be achieved on chamfering operations.
- Each insert has 4 cutting edges, reducing cost of inserts.
- Honed on the cutting edges, good chip breaking condition and long tool life.

NC2032 : K20F grade, AlTiN coated. For carbon steel, alloy steel and hardened steel as well as casting iron.

NC9071 : K20F grade, TiN coated, **high positive rake angle** and honed sharp edge. The best choice for low carbon steel, low alloy steel, stainless steel, Al, Al-alloy, Brass, Bronze and most of the non-ferrous metal.



NC2032



NC9071

- Please follow the cutting data to choose appropriate insert grade on page13.
- 31 means the insert has different chip breaker for tougher material applications.

Ordering code		Coated	Dimensions			Insert Screw	Screw Key	Apply for		
Code of insert	Grade		L	S	re			SPD	SD	Chamfer Mill
N9GX04T002	NC2032	AlTiN	4.0	1.8	0.2	NS-18037	NK-T6 / 0.6Nm	●	●	●
	NC9071	TiN								●
N9GX05T103	NC2032	AlTiN	5.0	2.0	0.2	NS-20045	NK-T6 / 0.8Nm	●	●	
N9GX060204	NC2032	AlTiN	6.35	2.38	0.4	NS-22055	NK-T7 / 1.0Nm	●	●	●
	NC9071	TiN								●
N9GX06020431*	NC40	TiN	6.35	2.38	0.4	NS-22055	NK-T7 / 1.0Nm	●		
N9GX070304	NC2032	AlTiN	7.94	3.18	0.4	NS-25060	NK-T7 / 1.2Nm		●	
N9GX090308	NC2032	AlTiN	9.52	3.18	0.8	NS-30072	NK-T9 / 2.0Nm	●	●	●
	NC9071	TiN								●
N9GX09030831*	NC40	TiN	9.52	3.18	0.8	NS-30072	NK-T9 / 2.0Nm	●		

Application of Drill in Different Conditions

Only for 3D-4D

Application	★ Regular Surface	Cross Holes	Stack Drilling	Round Work Piece Offset Drilling
Work Piece Shape				
Cutting Speed Vc (m/min.)	100%	80%	80%~70%	80%~60%
Feed Rate (mm/rev.)	100%	80%	80%~70%	80%~60%

Application	Plunge Drilling	Concave Surfaces	Angled Surfaces	Cone Work Piece Offset Drilling
Work Piece Shape				
Cutting Speed Vc (m/min.)	80%	80%	80%~70%	80%~70%
Feed Rate (mm/rev.)	80%	80%	80%~70%	80%~70%

★ SPD, SD both are suitable.

Adjustment on CNC Lathe

• Centre height on the lathe:

- The face of the inner edge must be 0-0.2 mm over the centre.
- The height of the inner edge can be adjusted by eccentric ring.

• Diameter of the drill:

- The diameter of the drilled hole can be adjusted along X-axis of the lathe. The maximum radial adjustment is shown on the specification of the product.

• Check the centre height of the inner insert:

- Drill 3 mm depth and check that there is a small pip at the centre of the bottom of the hole. The pip should be between 0.1mm and 0.5mm in diameter.
- If there is no pip; the inner insert must be adjusted to be over the centre.
- If the pip is larger than 0.5mm diameter; the centre of the drill should be adjusted lower.

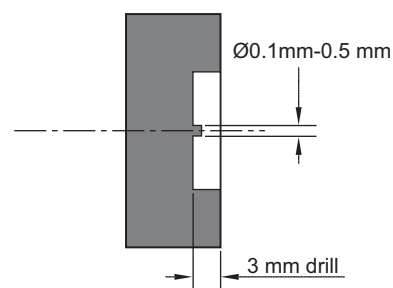
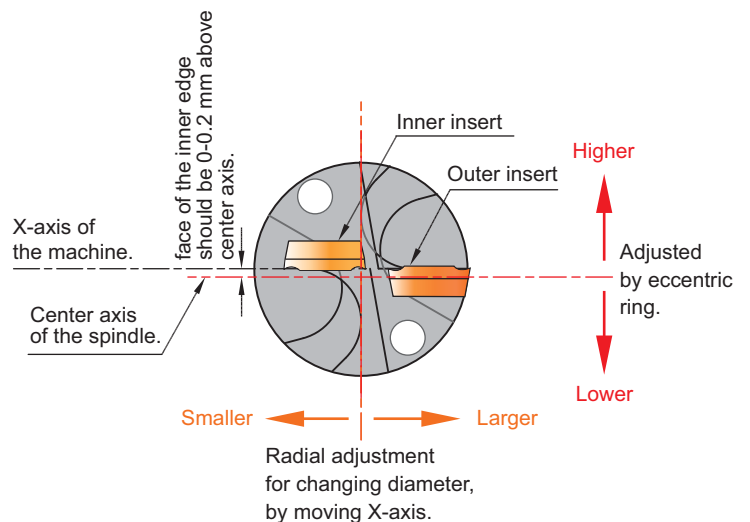

Cutting Data

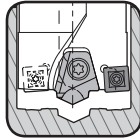

5D-10D

Work piece material	T= Length/ Dia.	Grade of insert		Vc (m/min.)	Feed rate f mm/rev.			
		Center	Periphery		N9GX04T002	N9GX05T103	N9GX060204	N9GX090308
					Dia.19	Dia.20-21	Dia.22-34	Dia.35-40
Carbon steel C<0.3% Ex.:S25C, SS41	T<7D	NC2032	NC2032	80~150	0.03~0.07	0.04~0.08	0.06~0.10	0.08~0.12
	T>7D			60~120	0.03~0.07	0.04~0.08	0.06~0.10	0.08~0.12
	T<7D	NC40	NC40	80~130	-	-	0.06~0.10	0.08~0.12
	T>7D			60~100	-	-	0.06~0.10	0.08~0.12
Carbon steel C>0.3% Ex.:S50C, P5	T<7D	NC40	NC2032	80~150	0.04~0.08	0.04~0.10	0.06~0.12	0.08~0.15
	T>7D			60~120	0.04~0.08	0.04~0.10	0.06~0.12	0.08~0.15
Low alloy steel C<0.3% Ex.:SCM415	T<7D	NC2032	NC2032	60~150	0.04~0.08	0.04~0.10	0.06~0.10	0.08~0.12
	T>7D			40~120	0.04~0.08	0.04~0.10	0.06~0.10	0.08~0.12
Low alloy steel C>0.3% Ex.:SCM440	T<7D	NC40	NC2032	60~150	0.04~0.08	0.04~0.10	0.06~0.12	0.08~0.15
	T>7D			40~120	0.04~0.08	0.04~0.10	0.06~0.12	0.08~0.15
High alloy steel Ex.:SKD11	T<7D	NC40	NC2032	60~120	0.03~0.07	0.04~0.08	0.06~0.10	0.08~0.12
	T>7D			40~100	0.03~0.07	0.04~0.08	0.06~0.10	0.08~0.12
Casting steel	T<7D	NC40	NC2032	60~120	0.03~0.07	0.04~0.08	0.06~0.10	0.08~0.12
	T>7D			40~100	0.03~0.07	0.04~0.08	0.06~0.10	0.08~0.12
Stainless steel Ex.:SUS304	T<7D	NC2032	NC2032	60~120	0.03~0.06	0.04~0.07	0.05~0.08	0.06~0.10
	T>7D			40~100	0.03~0.06	0.04~0.07	0.05~0.08	0.06~0.10
	T<7D	NC40	NC40	60~120	-	-	0.05~0.08	0.06~0.10
	T>7D			40~100	-	-	0.05~0.08	0.06~0.10
Casting Iron Ex.:FC25	T<7D	NC40	NC2032	60~120	0.04~0.08	0.04~0.10	0.06~0.10	0.08~0.12
	T>7D			40~100	0.04~0.08	0.04~0.10	0.06~0.10	0.08~0.12
Al, and non-ferrous metal Ex.:A6061	-	-	-	-	-	-	-	-
	-	-	-	-	-	-	-	-
Hardened steel <HRC 50° Ex.:SKD61	T<7D	NC40	NC2032	50~80	0.03~0.06	0.04~0.07	0.05~0.08	0.06~0.10
	T>7D			40~60	0.03~0.06	0.04~0.07	0.05~0.08	0.06~0.10

Important Information

- The cutting speed relates to the periphery inserts.
- Reduce feed rate 50% at the beginning of 3-5 mm.
- The feed rate depends on the load of the center pilot insert.
The best condition will create short cutting chips. The feed rate can be applied $\pm 25\%$ of the recommended value depended on the shape of the cutting chips.
- Be careful to monitor the spindle power consumption !
When the spindle load is 15% higher than starting power consumption, please change the periphery insert to next new cutting edge and change a new center pilot insert.
- Minimum coolant pressure is 10 bar (about 150 psi.). **Internal coolant is required.**
- Increase 20% of the cutting speed and the feed rate for horizontal spindle machine.
- For the CNC lathes, maximum miss-alignment of drill center and spindle center is ± 0.05 mm, it is not necessary to drill center hole in advance.

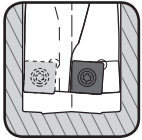

3D-4D

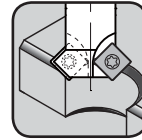

Chamfer Mill

Grade of insert	T= Length/ Dia.	Vc m/min.	Feed rate f mm/rev.				
			N9GX 04T002	N9GX 05T103	N9GX 060204	N9GX 070304	N9GX 090308
			Dia.10~12.5	Dia.13~15.5	Dia.16~19.5	Dia.20~24	Dia.25~30
NC2032	T=3D	80~250	0.03~0.06	0.04~0.08	0.06~0.10	0.06~0.10	0.08~0.12
	T=4D	60~180	-	-	0.06~0.10	0.06~0.10	0.08~0.12
NC2032	T=3D	80~300	0.04~0.08	0.06~0.10	0.06~0.12	0.08~0.12	0.08~0.15
	T=4D	60~150	-	-	0.06~0.12	0.08~0.12	0.08~0.15
NC2032	T=3D	80~250	0.04~0.08	0.04~0.08	0.06~0.10	0.06~0.10	0.08~0.12
	T=4D	60~150	-	-	0.06~0.10	0.06~0.10	0.08~0.12
NC2032	T=3D	80~250	0.04~0.08	0.04~0.10	0.06~0.12	0.06~0.12	0.08~0.15
	T=4D	60~150	-	-	0.06~0.12	0.06~0.12	0.08~0.15
NC2032	T=3D	60~150	0.03~0.06	0.04~0.08	0.06~0.10	0.06~0.10	0.08~0.12
	T=4D	50~100	-	-	0.06~0.10	0.06~0.10	0.08~0.12
NC2032	T=3D	80~180	0.03~0.06	0.04~0.08	0.06~0.10	0.06~0.10	0.08~0.12
	T=4D	60~120	-	-	0.06~0.10	0.06~0.10	0.08~0.12
NC2032	T=3D	60~150	0.03~0.06	0.04~0.08	0.04~0.10	0.06~0.10	0.06~0.12
	T=4D	50~100	-	-	0.04~0.10	0.06~0.10	0.06~0.12
NC2032	T=3D	80~120	0.04~0.08	0.06~0.08	0.06~0.08	0.06~0.10	0.08~0.12
	T=4D	60~100	-	-	0.06~0.08	0.06~0.10	0.08~0.12
-	-	-	-	-	-	-	-
	-	-	-	-	-	-	-
NC2032	T=3D	60~100	0.03~0.06	0.04~0.08	0.05~0.08	0.06~0.08	0.06~0.10
	T=4D	40~80	-	-	0.05~0.08	0.06~0.08	0.06~0.10

* The maximum misalignment of the drill center is +0.2 mm/-0.5 mm on the CNC lathe.

Grade of insert	Vc m/min.	Feed rate fz mm/tooth		
		N9GX 04T002	N9GX 060204	N9GX 090308
		Max. C 1.5 mm	Max. C 2.5 mm	Max. C 4 mm
NC9071	150~350	0.06~0.12	0.10~0.25	0.10~0.25
NC2032	200~400	0.06~0.10	0.10~0.20	0.10~0.25
NC9071	180~260	0.06~0.10	0.10~0.20	0.10~0.20
NC2032	120~200	0.06~0.10	0.10~0.15	0.10~0.15
NC2032	120~200	0.06~0.10	0.10~0.15	0.10~0.15
NC2032	120~200	0.06~0.10	0.10~0.15	0.10~0.15
NC9071	120~180	0.06~0.10	0.06~0.15	0.10~0.20
NC2032	120~180	0.06~0.10	0.10~0.15	0.10~0.20
NC9071	200~600	0.06~0.15	0.10~0.25	0.10~0.25
NC2032	80~100	0.06~0.10	0.06~0.12	0.10~0.15

* Not recommended for use with hand operated machines and hand held power tools.

Formulas of Spindle Speed and Feed Rate:

SPD, SD

Metric

$$\text{Spindle speed } S = \frac{Vc \times 1000}{\pi \times D} \text{ r.p.m}$$

$$\text{Feed rate} = f \times S \text{ mm/min.}$$

inch

$$SFM = Vc \text{ (m/min.)} \times 3.28$$

$$RPM = (3.82 \times SFM) / D$$

$$F = IPM = RPM \times f / 25.4$$

Chamfer mill

Metric

$$\text{Spindle speed } S = \frac{Vc \times 1000}{\pi \times C \text{min.}} \text{ r.p.m}$$

$$\text{Feed rate} = fz \times S \times Z \text{ mm/min.}$$

inch

$$SFM = Vc \text{ (m/min.)} \times 3.28$$

$$RPM = (3.82 \times SFM) / D$$

$$F = IPM = RPM \times fz \times Z / 25.4$$